

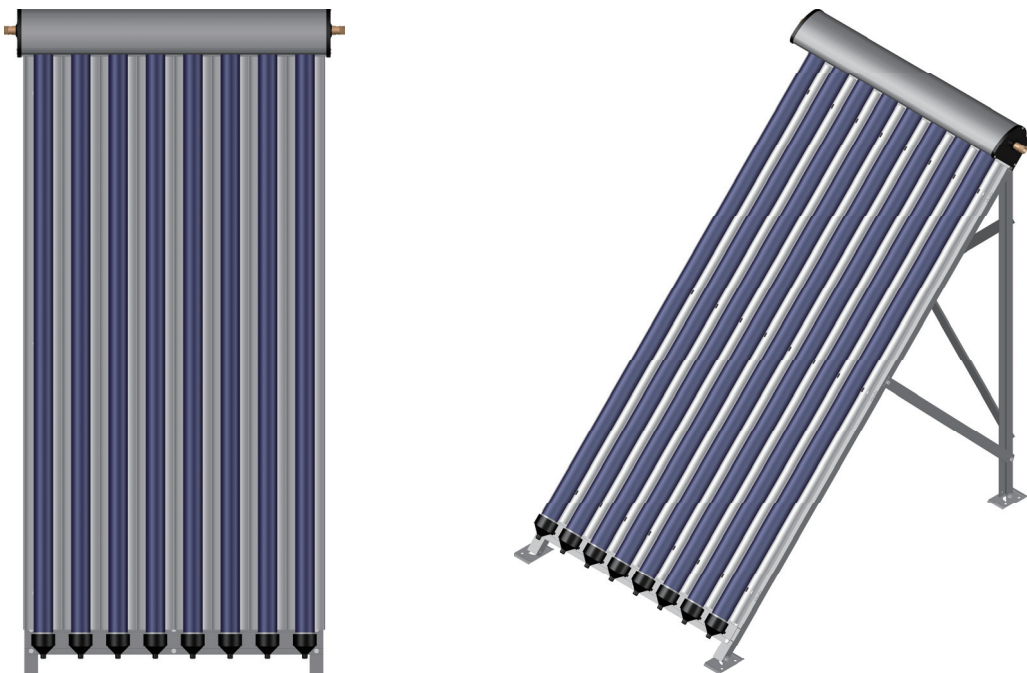

Tepto GbR.



Tepto CPC Solar Collector  
Installation & Maintenance Manual  
Model: Max CPC









(Version 1.1)



## Table of Contents

1. Safety information .....	4
2. Safety precautions .....	5
3. Solar collector direction .....	6
4. Parts list of solar collector .....	7
5. Installation .....	8
5.1 Solar collector size .....	8
5.2 Space requirement for pitched roofs .....	9
5.3 Solar collector schematic diagram .....	10
5.4 Install solar collector on pitched roof .....	11
5.4.1 Assemble the frames and manifold .....	11
5.4.2 Positioning roof hook .....	12
5.4.3 Roof hook installation .....	13
5.4.4 Installing the rails and frames .....	14
5.4.5 Installing the CPC reflector and heat pipe vacuum tube .....	15
5.5 Install flat roof collector .....	18
6. Lightning protection .....	22
7. How to connect couple of collectors .....	22
8. System connection schematic .....	23
9. Dimensions of pipe connections .....	25
10. Water quality .....	25
11. Heat transfer liquid .....	25
12. Installation precautions .....	26
13. Max. working pressure .....	26
14. Pressure drop at rated flow rate .....	26
15. Wind and snow load .....	26
16. Maintenance requirements .....	27
16.1. Cleaning .....	27
16.2. Leaves .....	27
16.3. Broken tube .....	27

## 1. Safety information

	<p>Safety precautions: before commencing mounting work on roofs, it must be ensured in all cases that the non-personal fall protection and fall-arrest systems required by (roof covering and roof sealing works) and (scaffolding works) are in place see also Builders Protection Ordinance, must be observed!</p>		<p>Contact with live electric overhead cables can be lethal.</p>
	<p>Never use damaged ladders (e.g., wooden ladders with split runners or rungs, or bent or buckled metal ladders). Never try to repair broken runners, rungs or steps on wooden ladders!</p>		<p>Whenever you are near live overhead electric cables where contact is possible, only work if:</p> <ul style="list-style-type: none"> <li>- it is ensured that they are voltage-free and this is secured for the duration of work.</li> <li>- the live parts are secured by covering them or cordoning them off.</li> <li>- the prescribed safety distances are maintained</li> </ul>
	<p>Only use safety harnesses (safety belts, lanyards and straps, shock absorbers, fall arresters) that were tested and certified by authorized testing bodies.</p>		<p>Voltage radius: 1m with.....voltages up to 1000V 3m with....voltages from 1000V to 11000V 4m with..voltages from 11000V to 22000V 5m with..voltages from 22000V to 38000V &gt; 5m in case of unknown voltages</p>
	<p>Ensure that ladders are put up safely. Observe the correct leaning angle (68° - 75°). Prevent ladders from sliding, falling over or sinking into the ground (e.g. using wider feet, feet suited to the ground or hooking devices).</p>		 <p>If non-personal fall protection or fall-arrest systems cannot be installed for technical reasons, all personnel must be secured by means of suitable safety harnesses!</p>
	<p>Only lean ladders against secure points. Secure ladders in traffic areas by suitable cordoning.</p>		 <p>Wear protective goggles when drilling or handling collectors.</p>
	<p>The manufacturer hereby guarantees to take back products identified with an eco-label and to recycle the materials used.</p>		
	<p>Only the heat transfer medium specified may be used!</p>		 <p>Wear safety shoes when carrying out installation work!</p>
	<p>Safety harnesses should be fixed above the users whenever possible. Safety harnesses should only be fastened to sufficiently load-bearing structures or fixing points!</p>		<p>Wear cut-proof safety gloves when carrying out installation work or handling collectors.</p>
	<p>If non-personal fall protection or fall-arrest systems are not provided, working without the use of suitable safety harnesses may lead to falls from heights and therefore cause serious or lethal injuries!</p>		
	<p>Ladders not properly secured against sinking in, sliding or falling over may lead to dangerous falls!</p>		 <p>Wear a helmet when carrying out installation work!</p>



## Warning!

For your safety, please read through this manual carefully before installation to minimize the risk of fire, property damage, and personal injury!

## 2. Safety precautions

### 2.1 Metallic componets

Always wear leather protective gloves when handling solar collector components. All efforts have been made to make the metal components safe to handle, but there may still be some sharp edges.

### 2.2 Vacuum tubes

- a) Be careful when handling the vacuum tubes, as they will break if knocked heavily or dropped.
- b) If exposed to sunlight and therefore hot (have internal pressure built up), the tubes may explode rather than implode if knocked and broken. This is a rare occurrence, but nevertheless safety precautions should be taken.
- c) If the vacuum tubes are struck by a hard object with sufficient force (ie. branch falling on roof), they may break. During installation, consideration should be taken as to the possible path any broken glass may take. Where possible protection should be implemented to prevent broken glass from reaching ground level where somebody could walk on it (ie. Guttering on roof).
- d) The home owner should be made aware by the Installer the location of the solar system and the possible vicinity of broken glass in the event of an extreme storm or object falling on the collector.

### 2.3 Health & safety

- a) Always wear safety glasses when handling vacuum tubes
- b) Adhere to safety regulations regarding working on roofs (or at a height)
- c) Always obtain engineer approval for installations in high wind regions.

### 2.4 Transportation

Safety is critical during lifting. Appropriate equipment must be used. Full safety and arrest training is essential. For hand lifting, assemblies and parts are lifted piece by piece to the elevated mounting location. The frame assembly is normally lifted first. Firmly anchor the frame. Then the tank is lifted and placed on the shoulder rests, and bolted down.

### 2.5 Snow and ice load

In region, where is rich of snow in winter, man should note the regulation of local construction bureau about the collector installation angle of inclination roof. Considering stacking of snow, moving of snow by wind and freezing of snow, the load of snow will increase, so it is necessary to take measure to avoid this situation happening.

### 2.6 Lightning protection

In installation location is prone to lightning strikes, it is advisable to earth/ground the copper circulation loop of the collector to avoid lightning related damage, or electrical safety issues. Refer also to local building codes regarding lightning safety and grounding.

## Before you start

- The assembly of the solar collector requires two able persons with the ability to lift 20KG each.
- Best to install on cloudy day.
- Store vacuum tubes in dark or shaded place until insertion into the manifold.

- Do not remove and/or expose the tubes to sunlight until ready to install, otherwise the heat pipe tip will become very hot, sufficient to cause serious skin burns. The outer glass surface will not become hot.

NEVER TOUCH THE INSIDE OF THE VACUUM TUBE OR HEAT PIPE CONDENSER AFTER EXPOSURE TO SUNLIGHT. WEAR THICK LEATHER GLOVES IF HANDLING THE HEAT PIPE.

### 3. Solar collector direction

The first rule of deciding the angle and direction of your solar collector is:

- In the northern hemisphere: Your collector should face south
- In the southern hemisphere: Your collector should face north

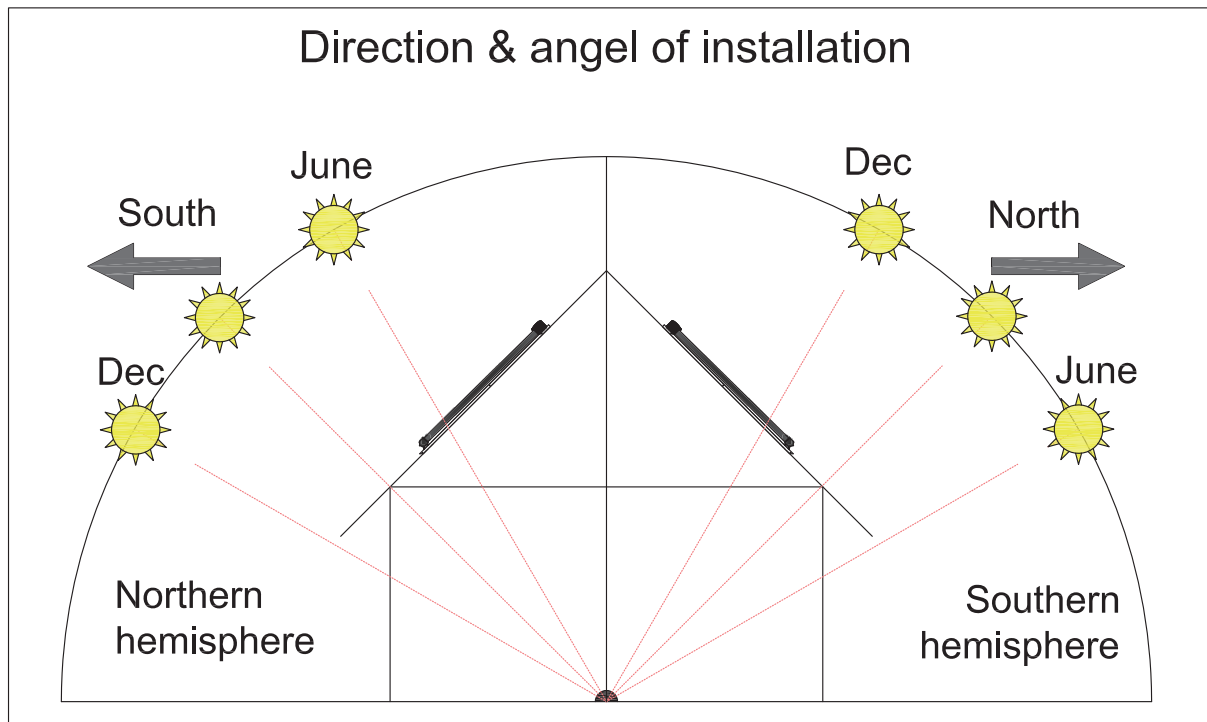

The general rule of thumb is to install your solar collectors at your Latitude plus 10 degrees.

Please note – if your roof is within +/- 10 degrees of the recommended angle for your collector, then you are fine with mounting the solar collectors flush to the roof. The added cost and work of installing the collectors on a tilt mount in this case is not warranted as the increase in efficiency would not be significant enough.

















Seasonal Changes in Heat Output – Prevent Excessive Summer Heat

Try mounting your solar panels 20 degrees higher than the latitude of your location calls for (ie, 50 degrees instead of 30 degrees). In the winter, you will get additional performance because the more vertical solar collector is more in line with the sun that is closer to the horizon – this increases your winter output dramatically. In the summer, you will get lower than standard performance because the more vertical solar collector is angled more away from the sun as it is higher in the sky – this allows you to get enough heat output for your needs without the need to worry about excessive heat and damage to your system or home.



The minimum collector mounting angle can not be lower than 10 degrees

#### 4. Parts list of solar collector

A			
B			
C			
D			
E			
F			
G			
H			
I			
J		K	
L			
M		N	 M8*20MM
O	 M8*25MM	P	 M8*50MM
Q			

## 5. Installation

### 5.1 Solar collector size

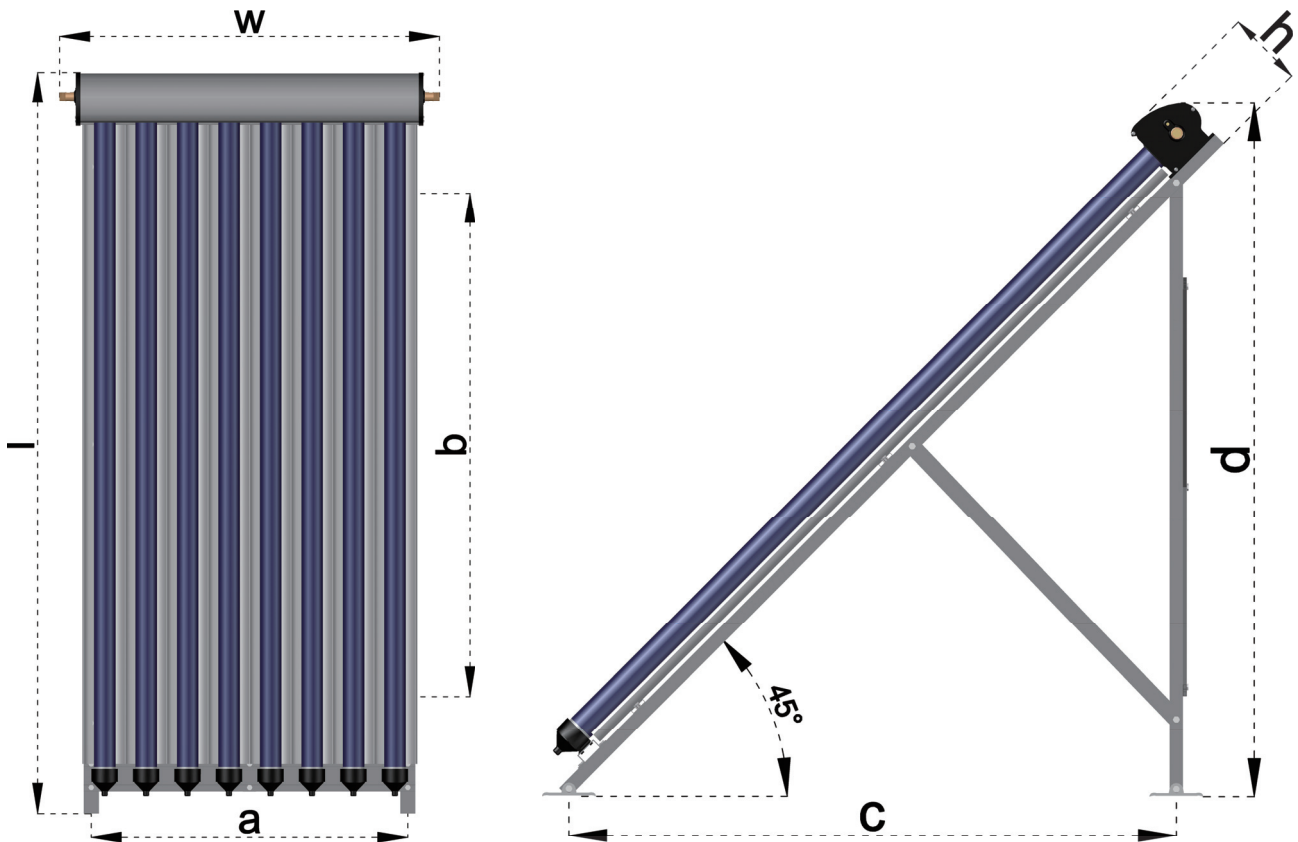

NO.	Model	Heat Pipe Vacuum Tube			Figure Size (l×w×h)(mm)	Installation Size	
		Qty.(pcs)	Dia.(mm)	Len.(mm)		(a×b) (mm)	(c×d) (mm)
1	Max CPC8	8	58	1800	1970×1010×160	840×1340	1320×1425
2	Max CPC9	9	58	1800	1970×1120×160	950×1340	1320×1425
3	Max CPC10	10	58	1800	1970×1230×160	1060×1340	1320×1425
4	Max CPC12	12	58	1800	1970×1450×160	1280×1340	1320×1425
5	Max CPC14	14	58	1800	1970×1670×160	1500×1340	1320×1425
6	Max CPC15	15	58	1800	1970×1780×160	1610×1340	1320×1425
7	Max CPC16	16	58	1800	1970×1890×160	1720×1340	1320×1425
8	Max CPC18	18	58	1800	1970×2110×160	1940×1340	1320×1425
9	Max CPC20	20	58	1800	1970×2330×160	2160×1340	1320×1425
10	Max CPC22	22	58	1800	1970×2550×160	2380×1340	1320×1425
11	Max CPC24	24	58	1800	1970×2770×160	2600×1340	1320×1425



## 5.2 Space requirement for pitched roofs

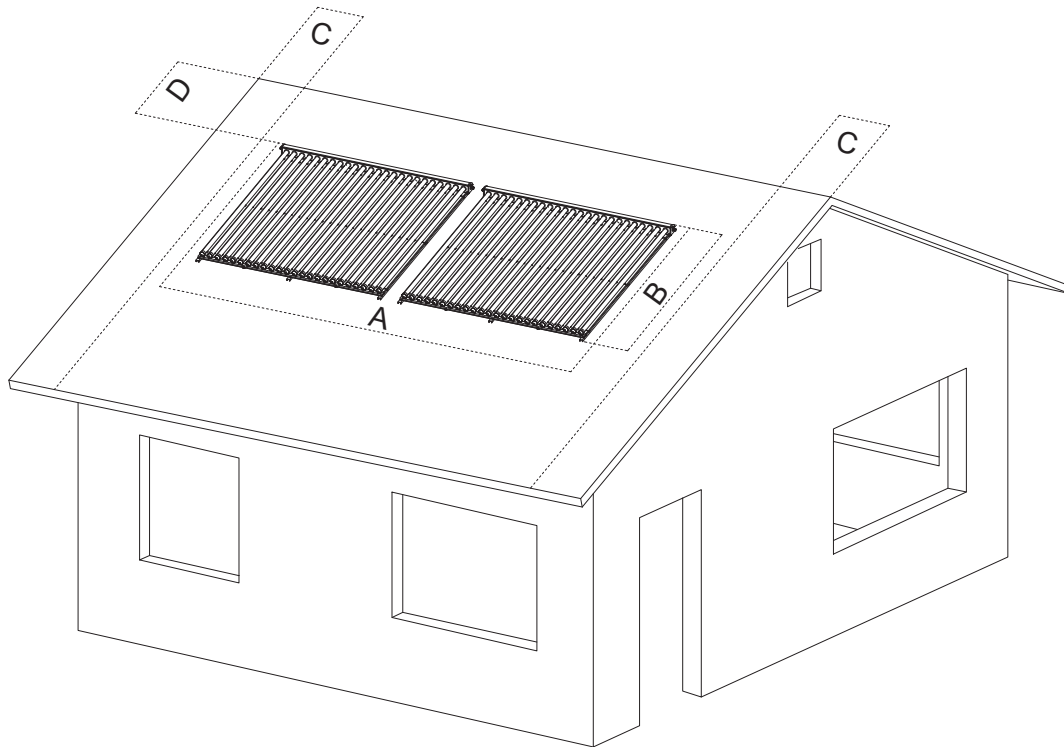

Dimension A (Column of collector array)

Collector No.	CPC8 (m)	CPC9 (m)	CPC10 (m)	CPC12 (m)	CPC14 (m)	CPC15 (m)	CPC16 (m)	CPC18 (m)	CPC20 (m)	CPC22 (m)	CPC24 (m)
1	1.01	1.12	1.23	1.45	1.67	1.78	1.89	2.11	2.33	2.55	2.77
2	2.12	2.34	2.56	3	3.44	3.66	3.88	4.32	4.76	5.20	5.64
3	3.23	3.56	3.89	4.55	5.21	5.54	5.87	6.53	7.19	7.85	8.51
4	4.34	4.78	5.22	6.1	6.98	7.42	7.86	8.74	9.62	10.50	11.38
5	5.45	6	6.55	7.65	8.75	9.30	9.85	10.95	12.05		
6	6.56	7.22	7.88	9.2	10.52	11.18	11.84				

Note: All the models name in the above table are abbreviated. In fact, CPC8 full name is Max CPC8.... CPC24 full name is Max CPC24

Dimension B (Row of collector array)

Collector No.	Max CPC (m)
1	2
2	4.15
3	6.3

### Dimension C

Corresponds to the roof overhang including the thickness of the end wall. The adjoining 0.30m(0.30m is only for reference, specifically according to local laws and regulations) distance from the collector is required for hydraulic connection below the roof.

### Dimension D

Represents a minimum of 3 pan tile rows to the ridge. If this is not observed, there arises a risk of damage to the roof cladding at the ridge, especially on wet-laid pan tiles.

### 5.3 Solar collector schematic diagram

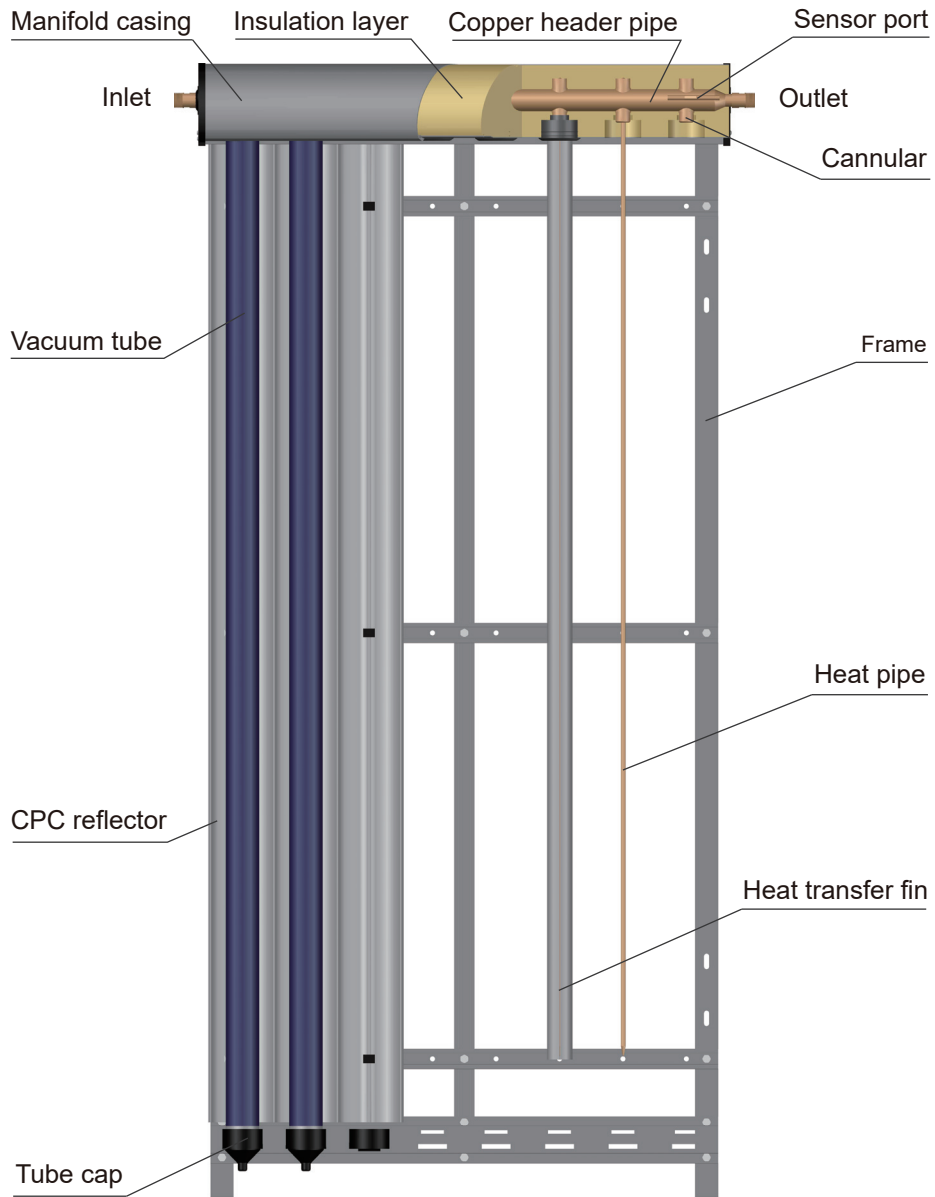

## 5.4 Install solar collector on pitched roof

### 5.4.1 Assemble the frames and manifold

1. Unscrew the nut on the manifold, put the manifold(A) back up, install the front legs(B) and vertical bar(C) on the back of manifold, tighten nut on the manifold.
2. Turn the tail stock(D) back up, install the tail stock on the front legs(B) and vertical bar(C), tighten nuts.
3. Install the horizontal bar(E), tighten the nuts between front legs and vertical bar.

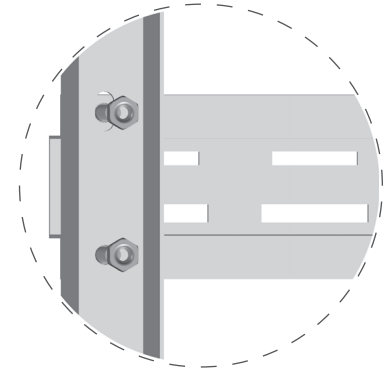
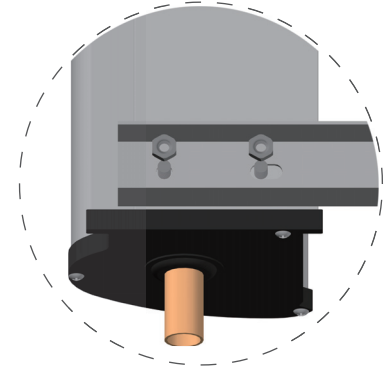
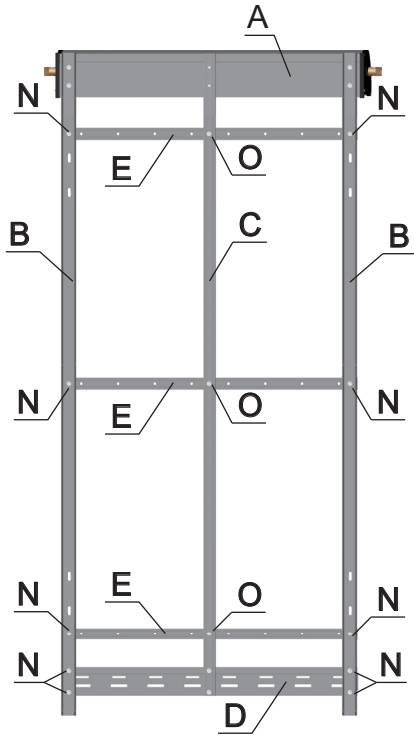

\*Applicable model: Max CPC8/9/10/12/14/15.

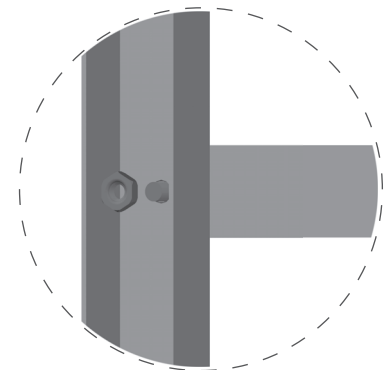
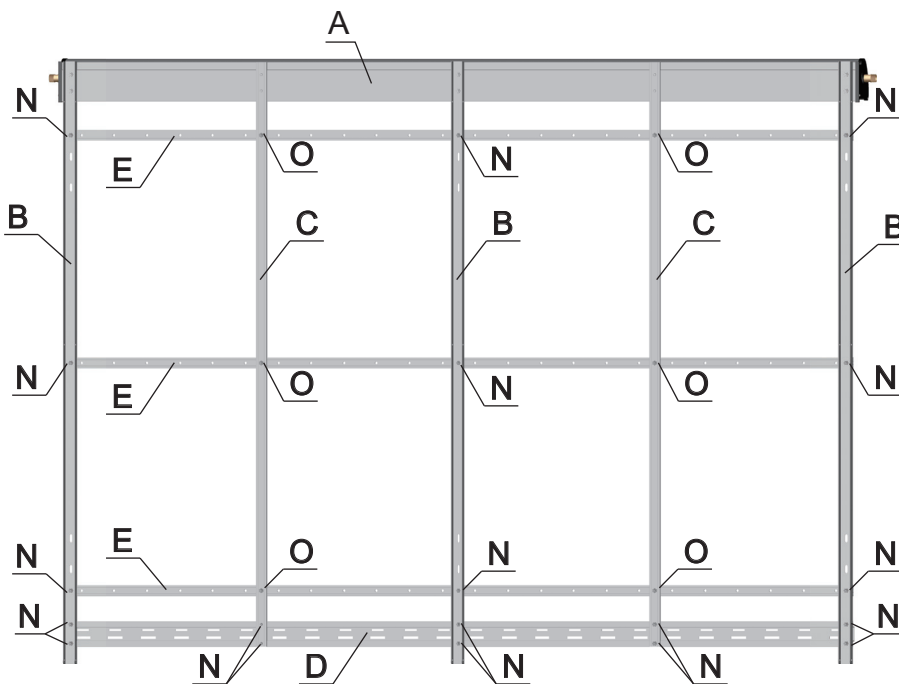

\*Applicable model: Max CPC16/18/20/22/24.

### 5.4.2 Positioning roof hook

\*This installation method is only for reference, and the specific installation is based on the actual situation of roof.

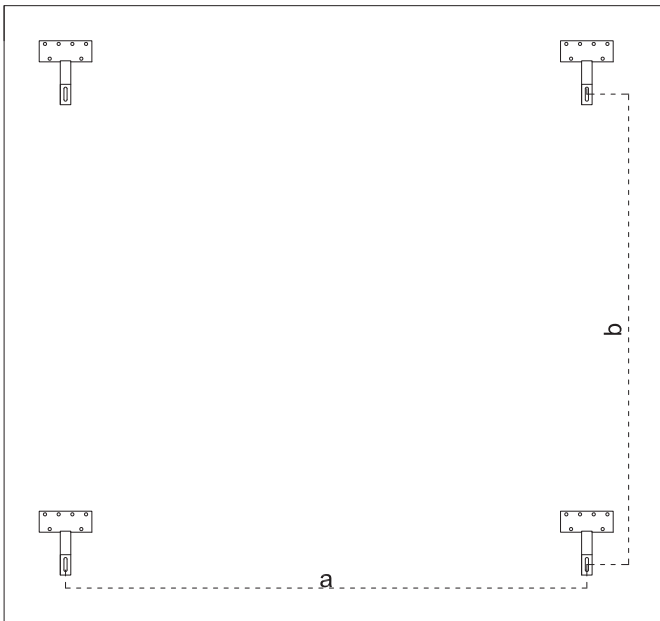

Model	Max CPC8	Max CPC9	Max CPC10	Max CPC12	Max CPC14	Max CPC15
a	840mm	950mm	1060mm	1280mm	1500mm	1610mm
b	1340mm, 1240mm, 1140mm (All sizes are available)					

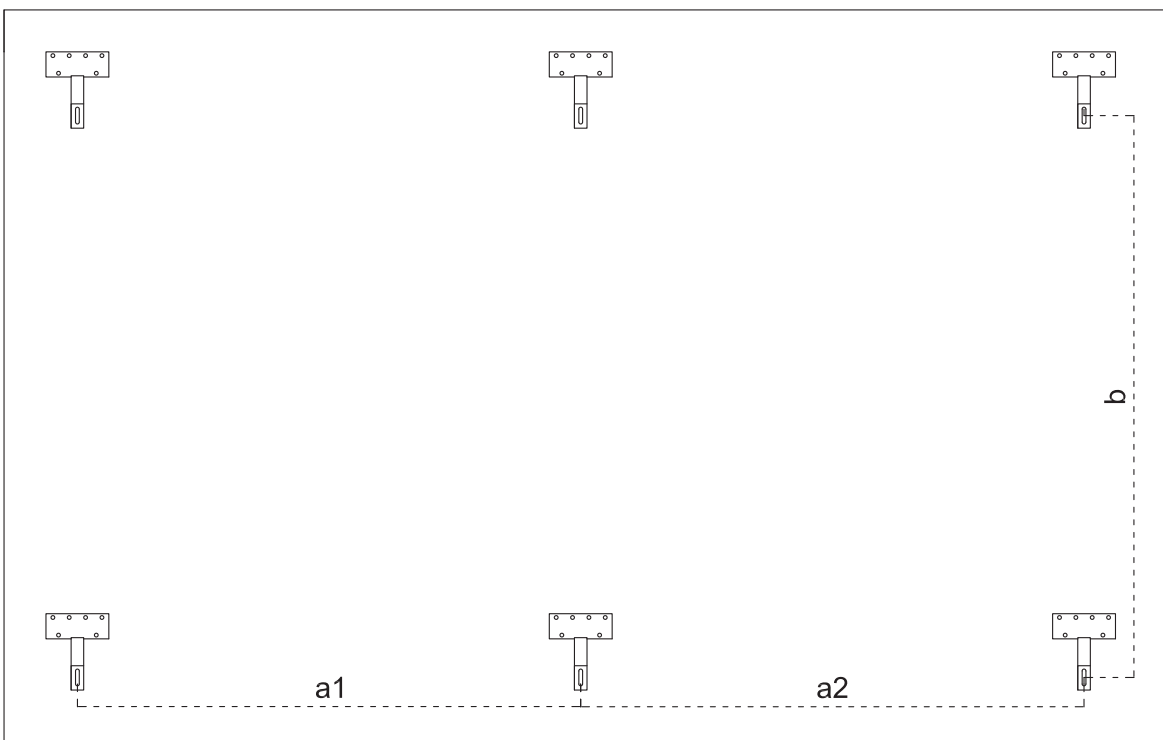

Model	Max CPC16	Max CPC18	Max CPC20	Max CPC22	Max CPC24
a1	860mm	970mm	1080mm	1190mm	1300mm
a2					
b	1340mm, 1240mm, 1140mm (All sizes are available)				

### 5.4.3 Roof hook installation

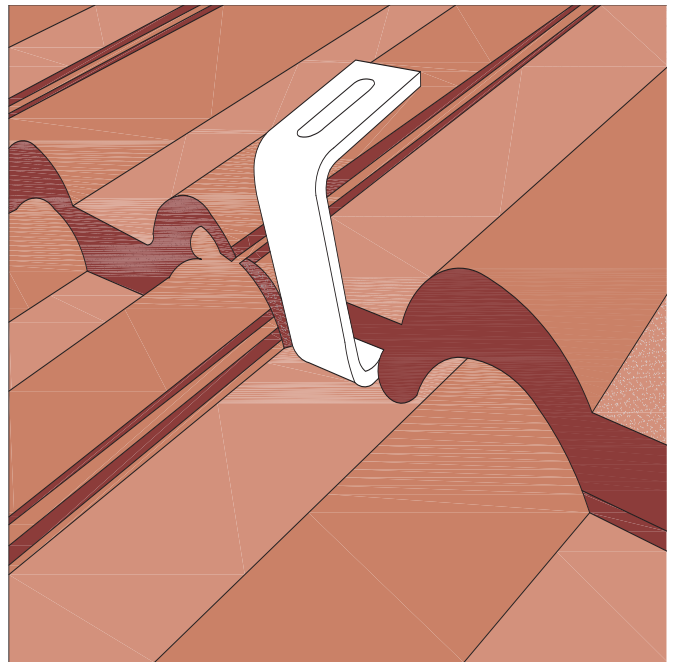
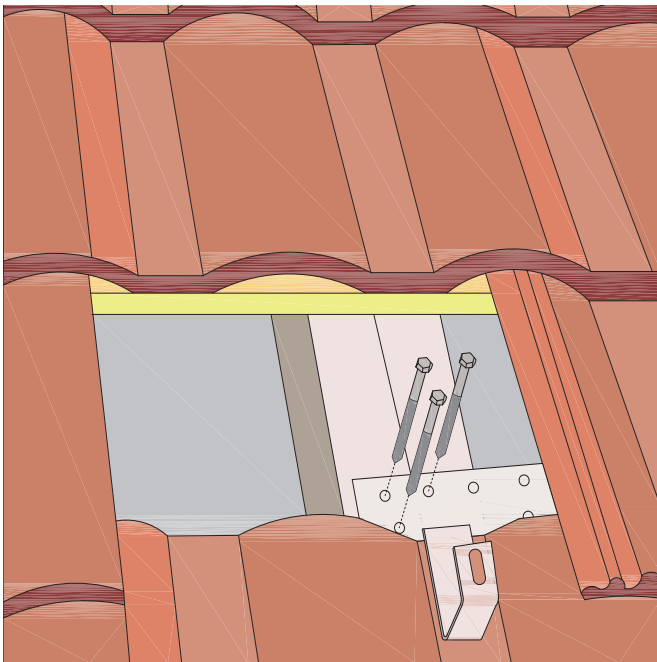
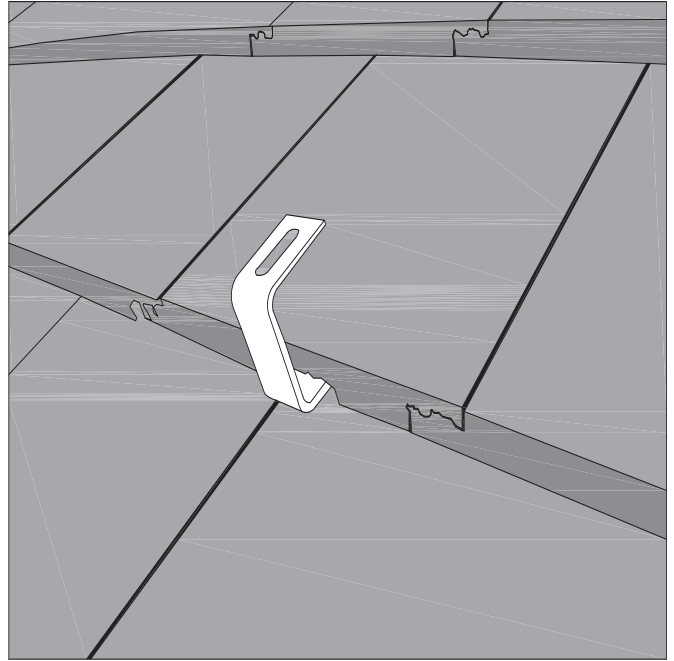
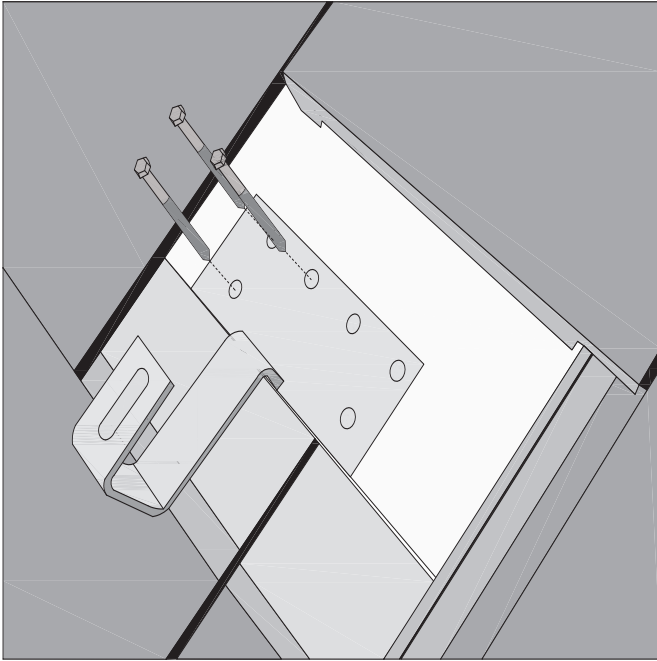

#### 5.4.4 Installing the rails and frames

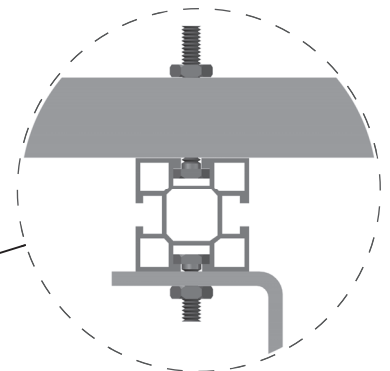
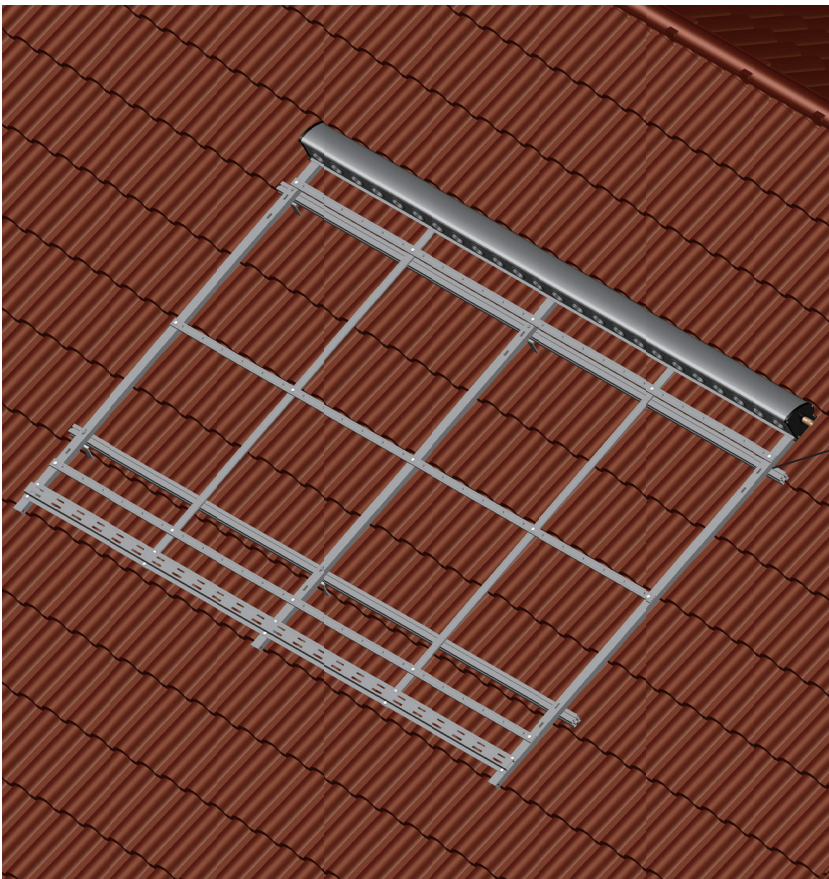
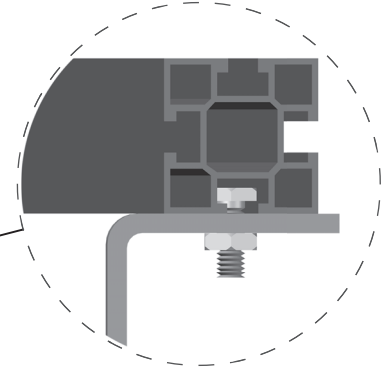
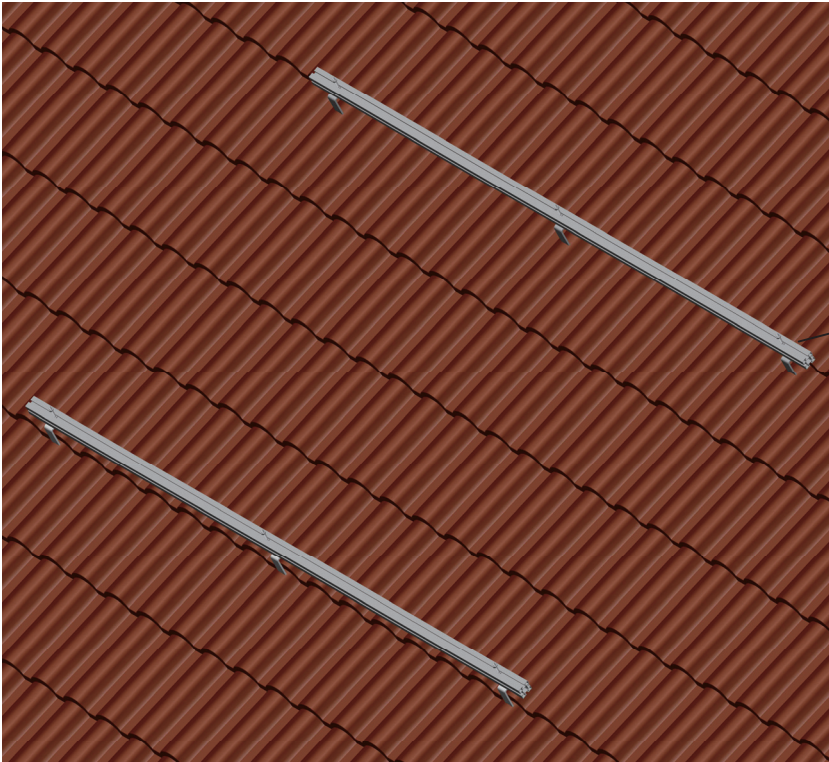

### 5.4.5 Installing the CPC reflector and heat pipe vacuum tube

\*Applicable model: Max CPC8/9/10/12/14/15.

1. Install the tube cap(K).
2. Place the CPC reflector(F) on the horizontal bars(E), install 3 fastening(J), tighten it.

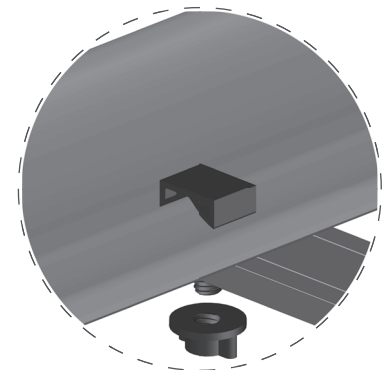
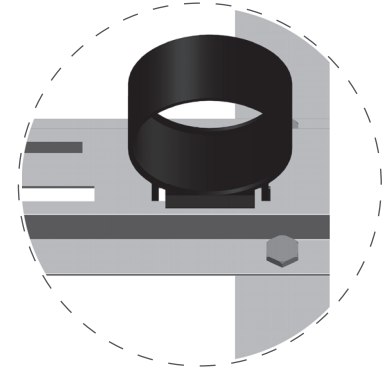
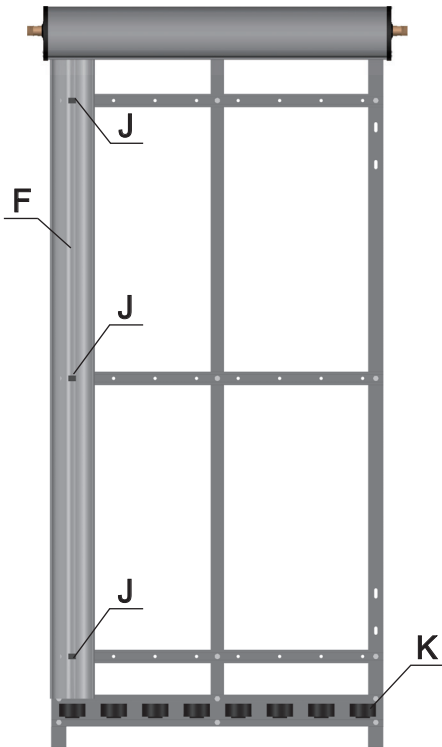

3. Pull the heat pipe out a little, smear silicone grease(M) on the surface of heat pipe condenser(Used to increase energy transfer efficiency), insert heat pipe condensor into the manifold hole, make sure it reaches the end, and contacts tightly.

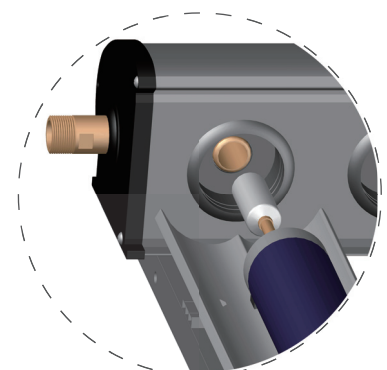
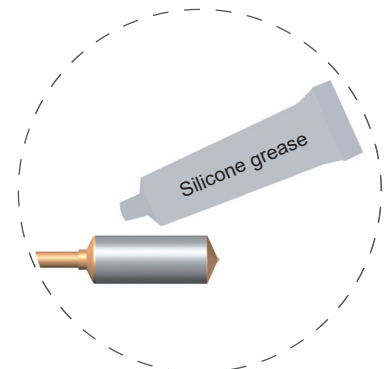
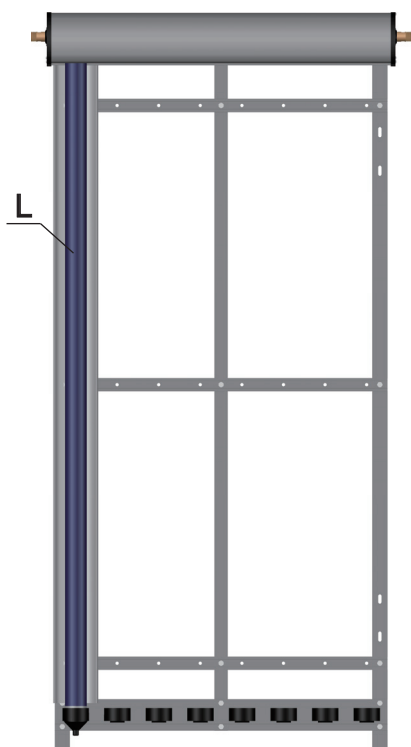

4. Then plug in the vacuum tube, and make sure it fixed with dust ring well, tighten the tube cap(K) clockwise.
5. Check everything and finish the CPC solar collector installation.

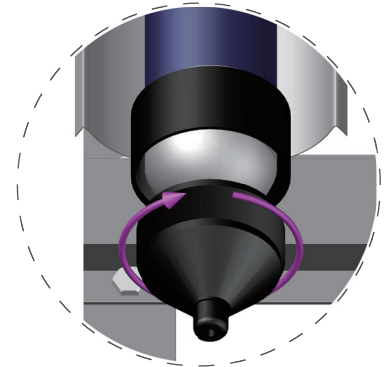
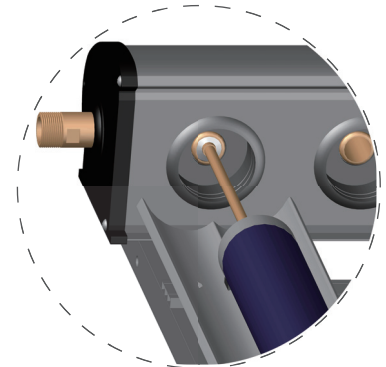
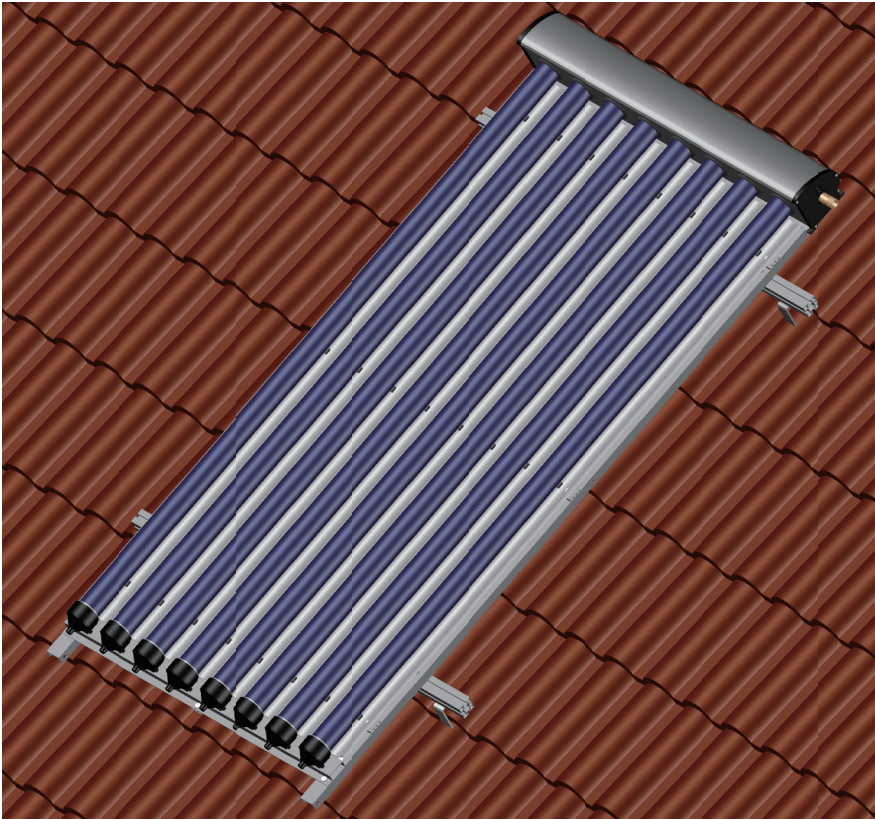

\*Applicable model: Max CPC16/18/20/22/24.

1. Install the tube cap(K).
2. Place the CPC reflector(F) on the horizontal bars(E), install 3 fastening(J), tighten it.

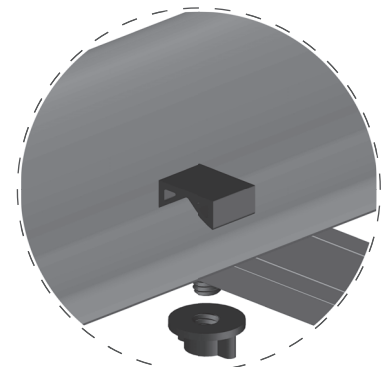
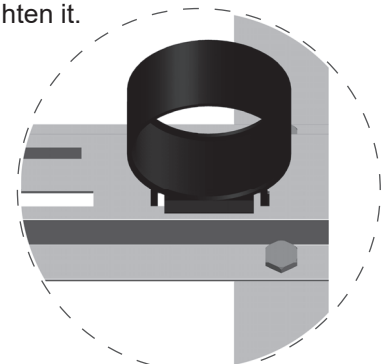
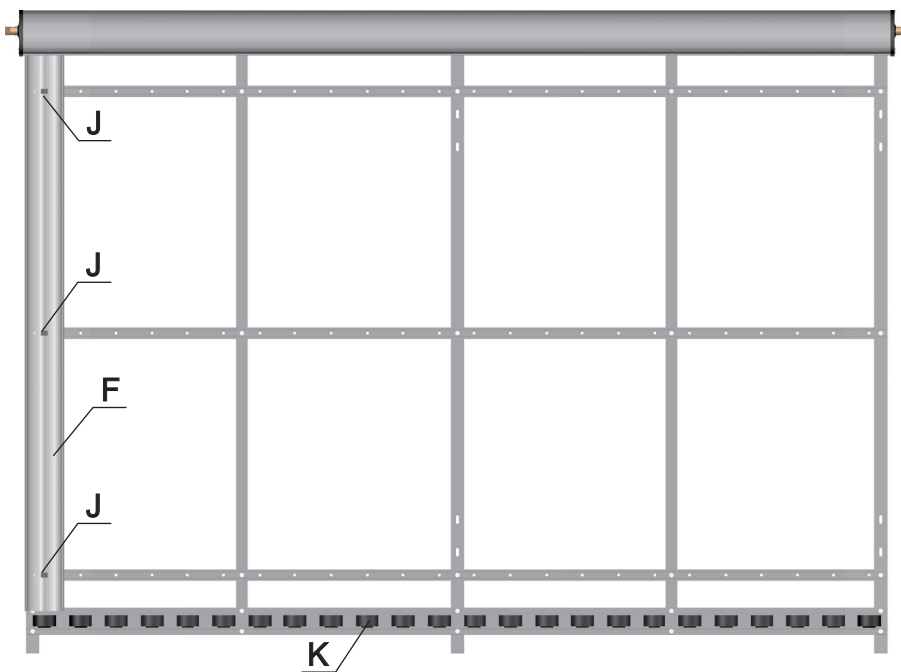



3. Pull the heat pipe out a little, smear silicone grease(M) on the surface of heat pipe condenser(Used to increase energy transfer efficiency), insert heat pipe condensor into the manifold hole, make sure it reaches the end, and contacts tightly.

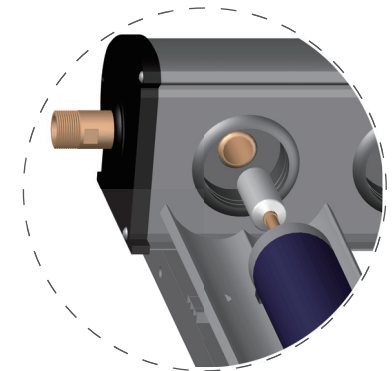
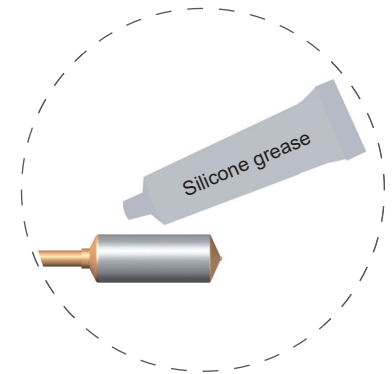
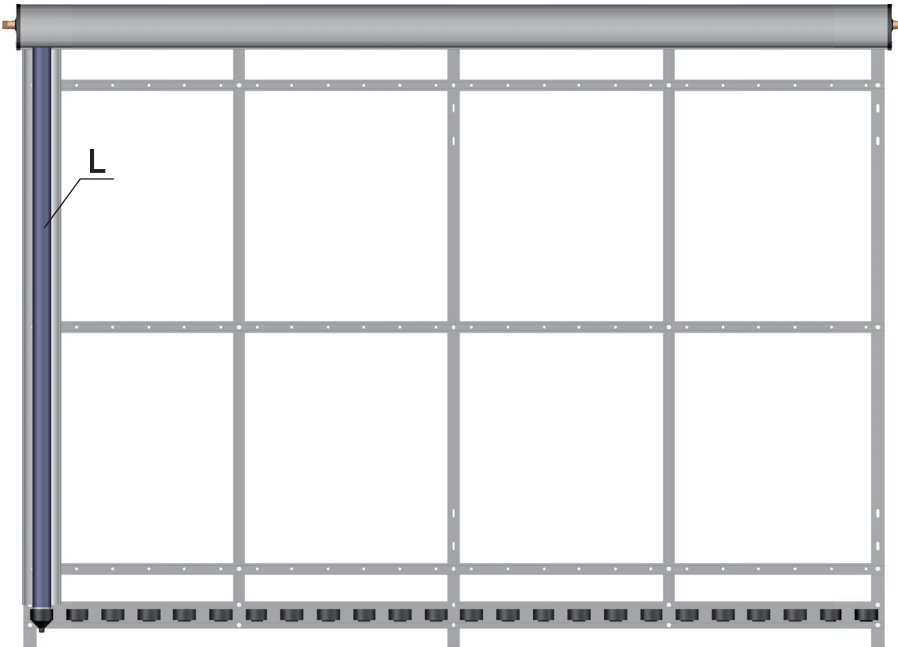

4. Then plug in the vacuum tube, and make sure it fixed with dust ring well, tighten the cap clockwise.
5. Check everything and finish the CPC solar collector installation.

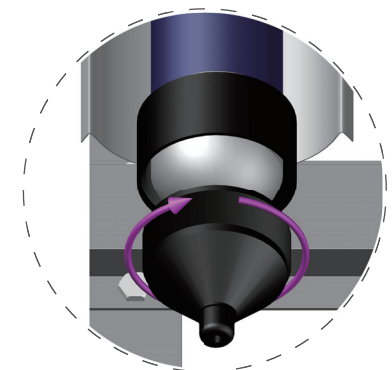
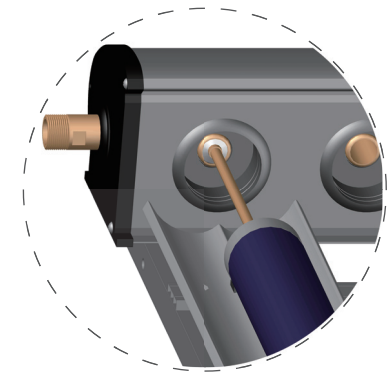
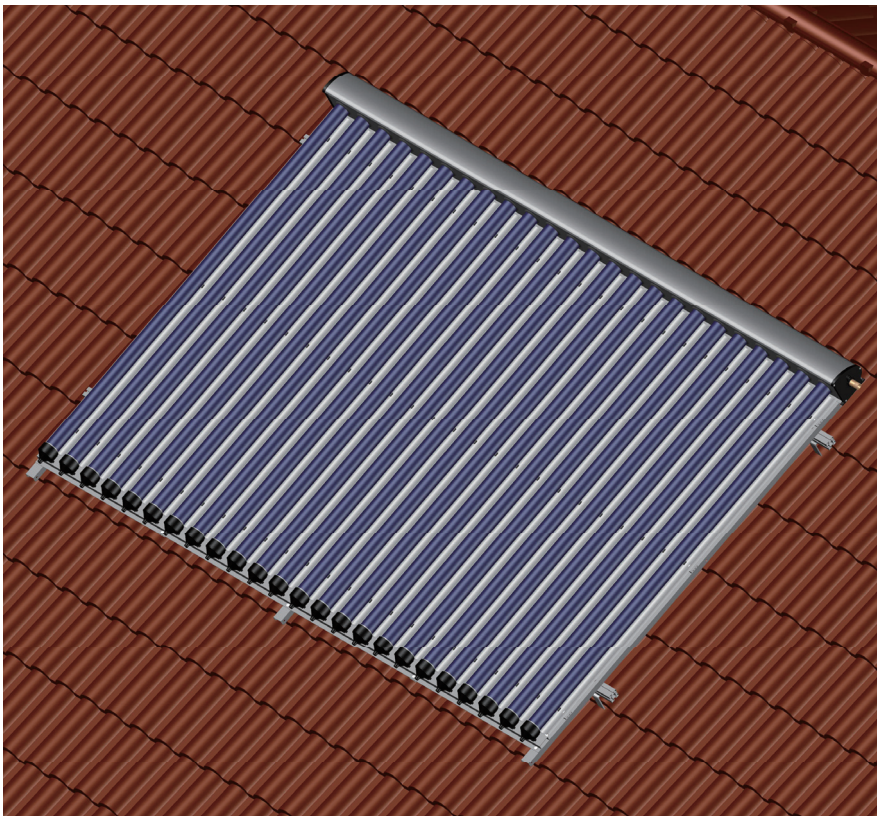

### 5.5 Install solar collector on flat roof

\*Applicable model: Max CPC8/9/10/12/14/15.

1. Install frame and manifold, please refer to page 11.
2. Install rear legs(G), Install tilt bars(H) between the front legs(B) and rear legs(G), Install cross bars(I) between the rear legs to create an "X". Install windproof foot(Q) on G and B.

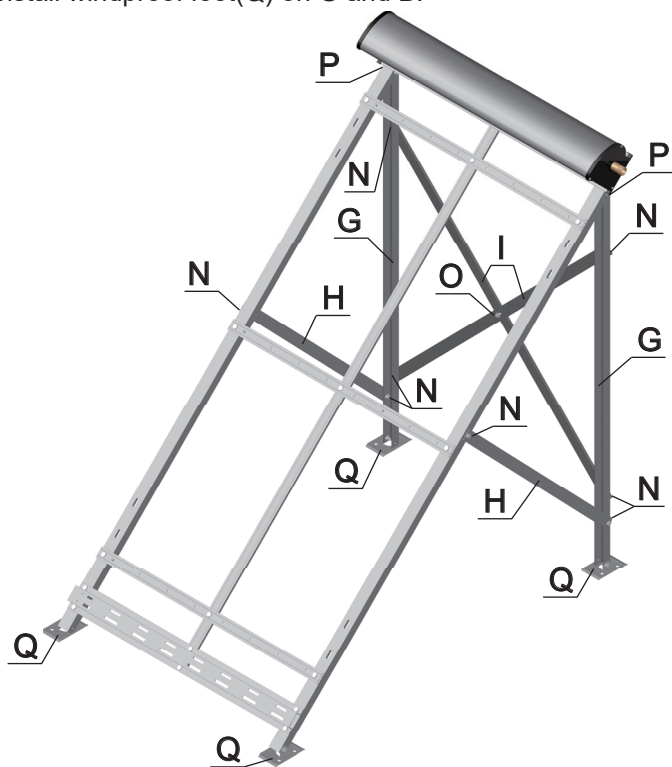

3. Install the tube cap(K).

4. Place the CPC reflector(F) on the horizontal bars(E), install 3 fastening(J), tighten it.

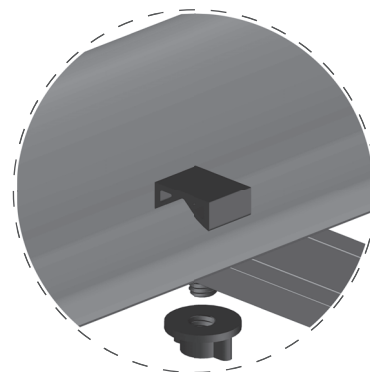
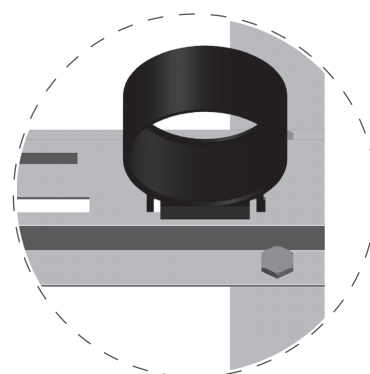
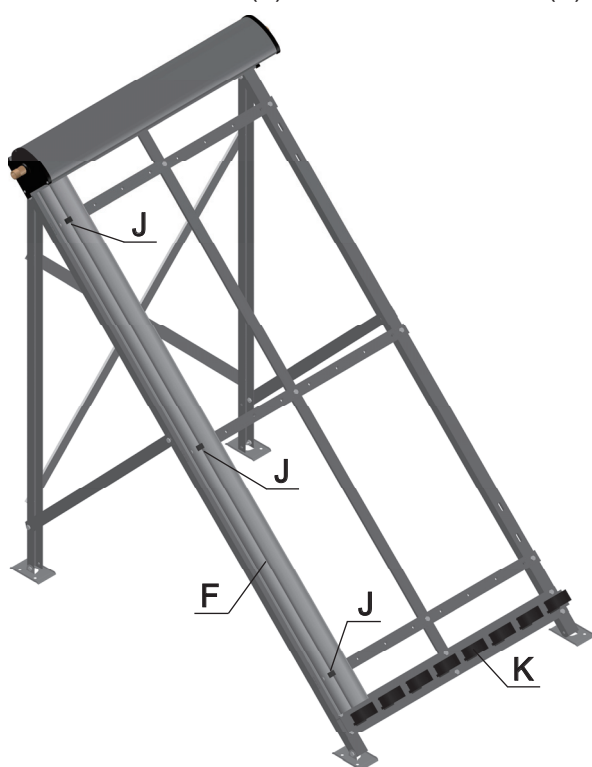

5. Install the heat pipe vacuum tube(L), please refer to page 15-16.

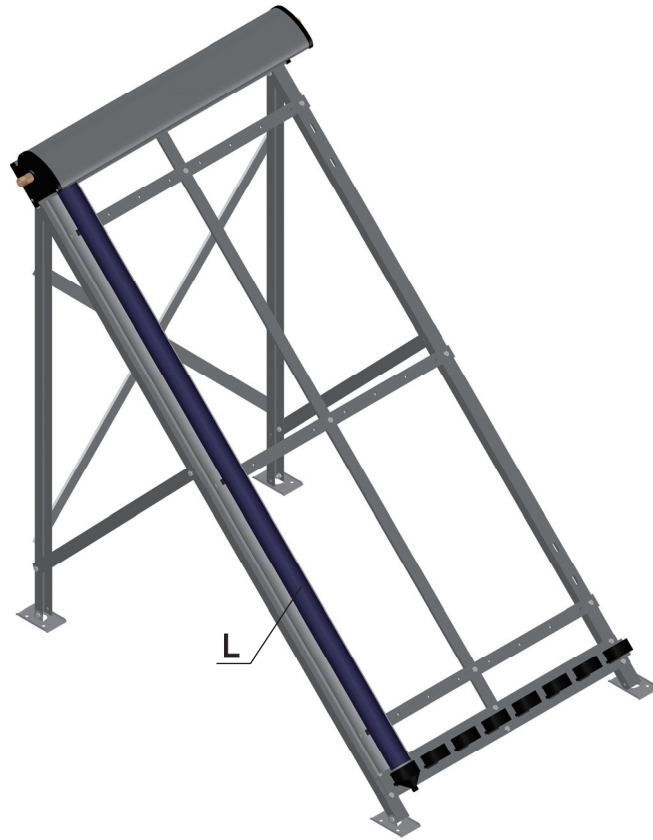

6. Check everything and finish the solar collector installation.



\*Applicable model: Max CPC16/18/20/22/24.

1. Install frame and manifold, please refer to page 11.
2. Install rear legs(G), Install tilt bars(H) between the front legs(B) and rear legs(G), Install cross bars(I) between the rear legs to create an "X". Install windproof foot(Q) on G and B.

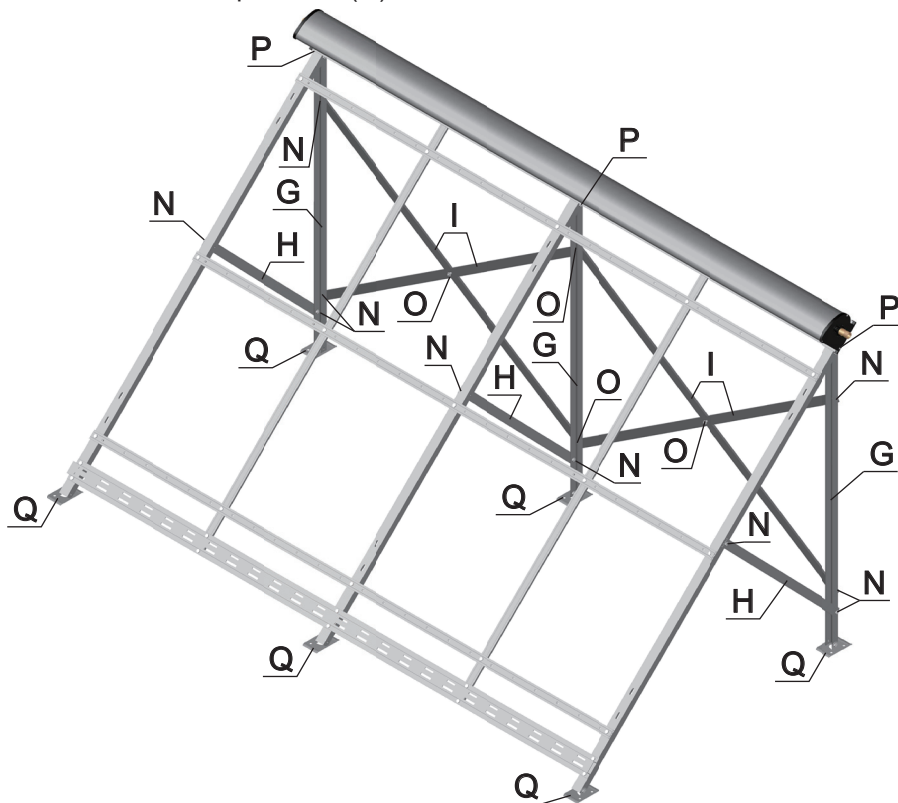

3. Install the tube cap(K).

4. Place the CPC reflector(F) on the horizontal bars(E), install 3 fastening(J), tighten it.

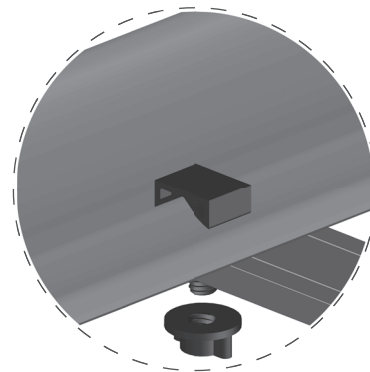
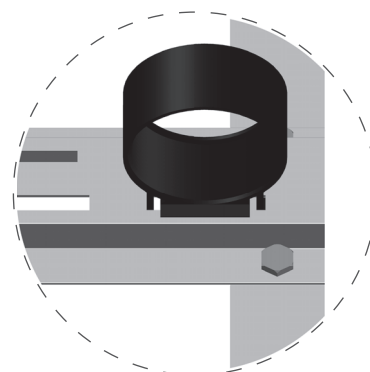
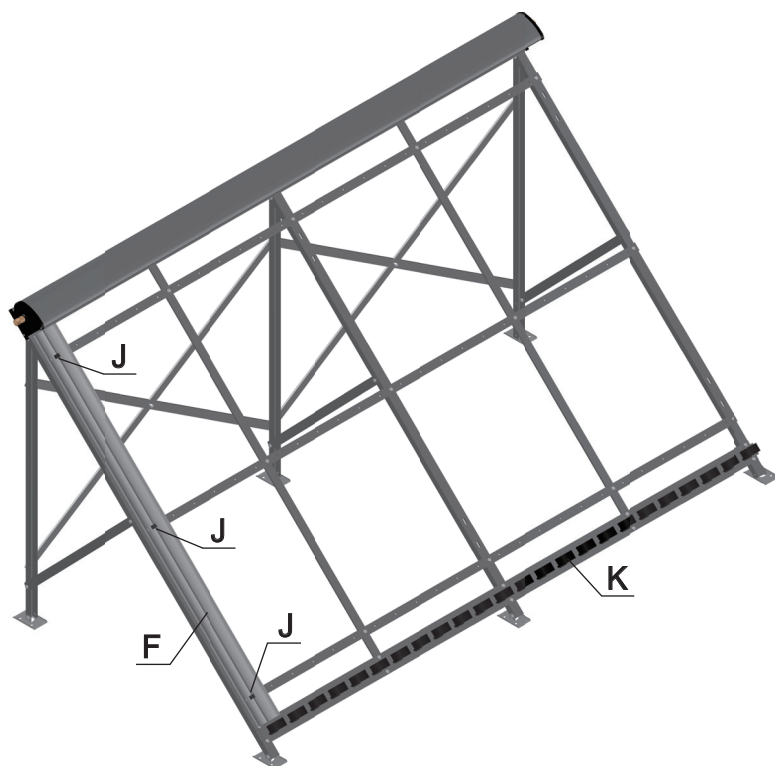

5. Install the heat pipe vacuum tube(L), please refer to page 15-16.



6. Check everything and finish the solar collector installation.

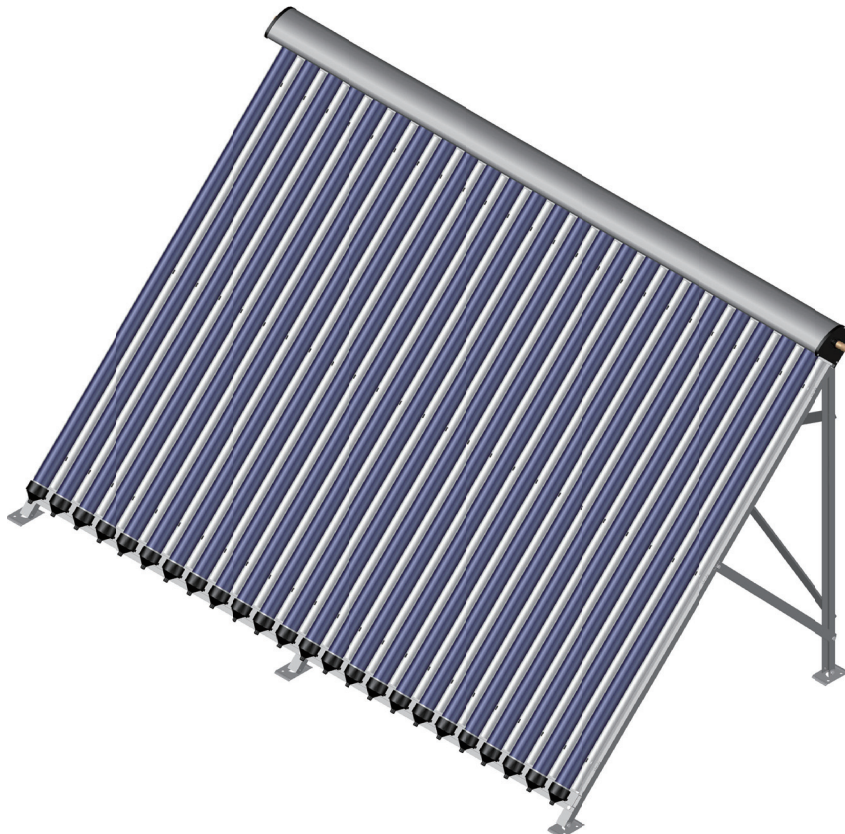

## Warning!

If you assemble solar collectors under strong sunshine, or the ambient temperature is high, it's forbidden to touch the two copper pipes' ends by hand directly. Because once tubes are exposed under sunshine, they begin to work. The heat will be transferred to the top of heat pipes in seconds. Therefore, the two ends of copper pipes are very hot after you finished the assembly. Touch it directly will scald skin! You also can cover a blanket to tubes to avoid it.

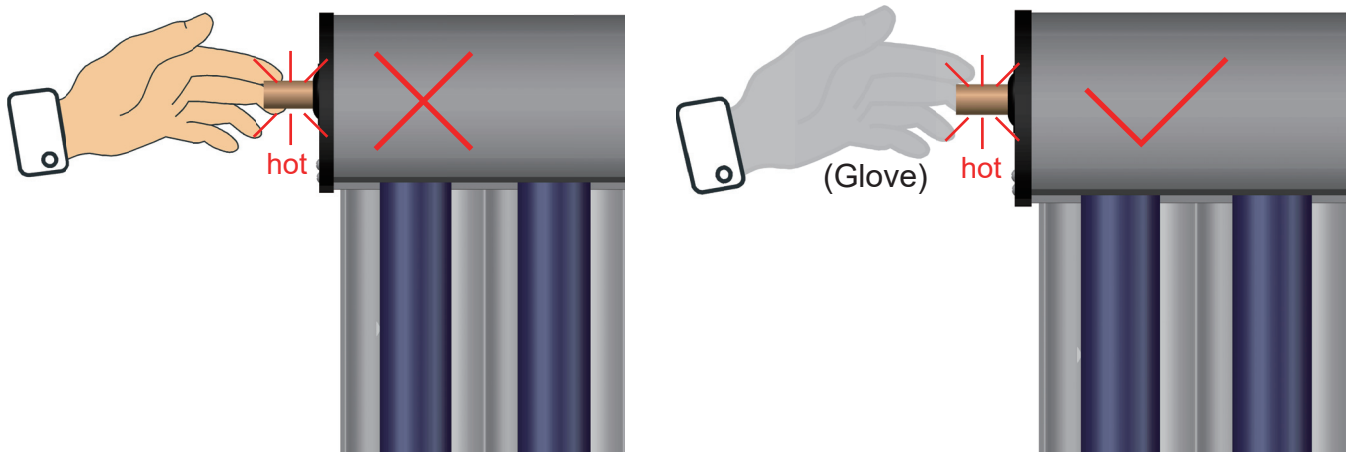

## Suggestions:

1. The assembly process is best to be finished in the shade.
2. If the process has to be finished under sunshine, you can cover the inserted tubes by black cloth, etc.

## 6. Lightning protection

The collectors should be done lightning protecting to avoid the lightning attacking. The lightning rod is necessary which should be 1.5m higher and 3 m far away from the solar collectors. For any problems that involve plumbing or electrical connections the services of a qualified professional must be employed.

## 7. How to connect couple of collectors

We suggest you use the corrugated connection pipe (or U type copper pipe) to connect every two solar collectors, which is very convenient and completely fit two solar collectors.

Please see the following picture.

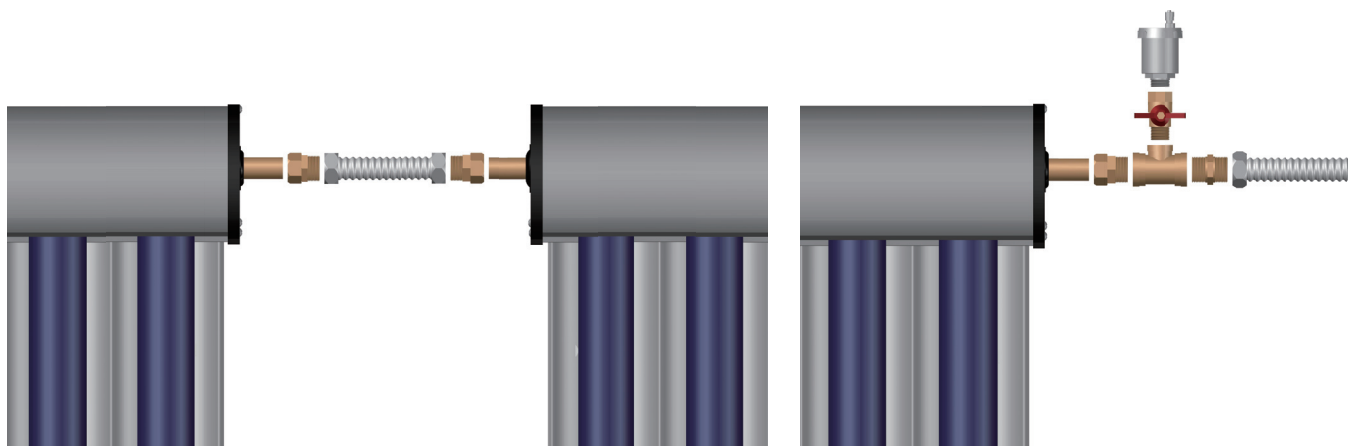

### 8. System connection schematic

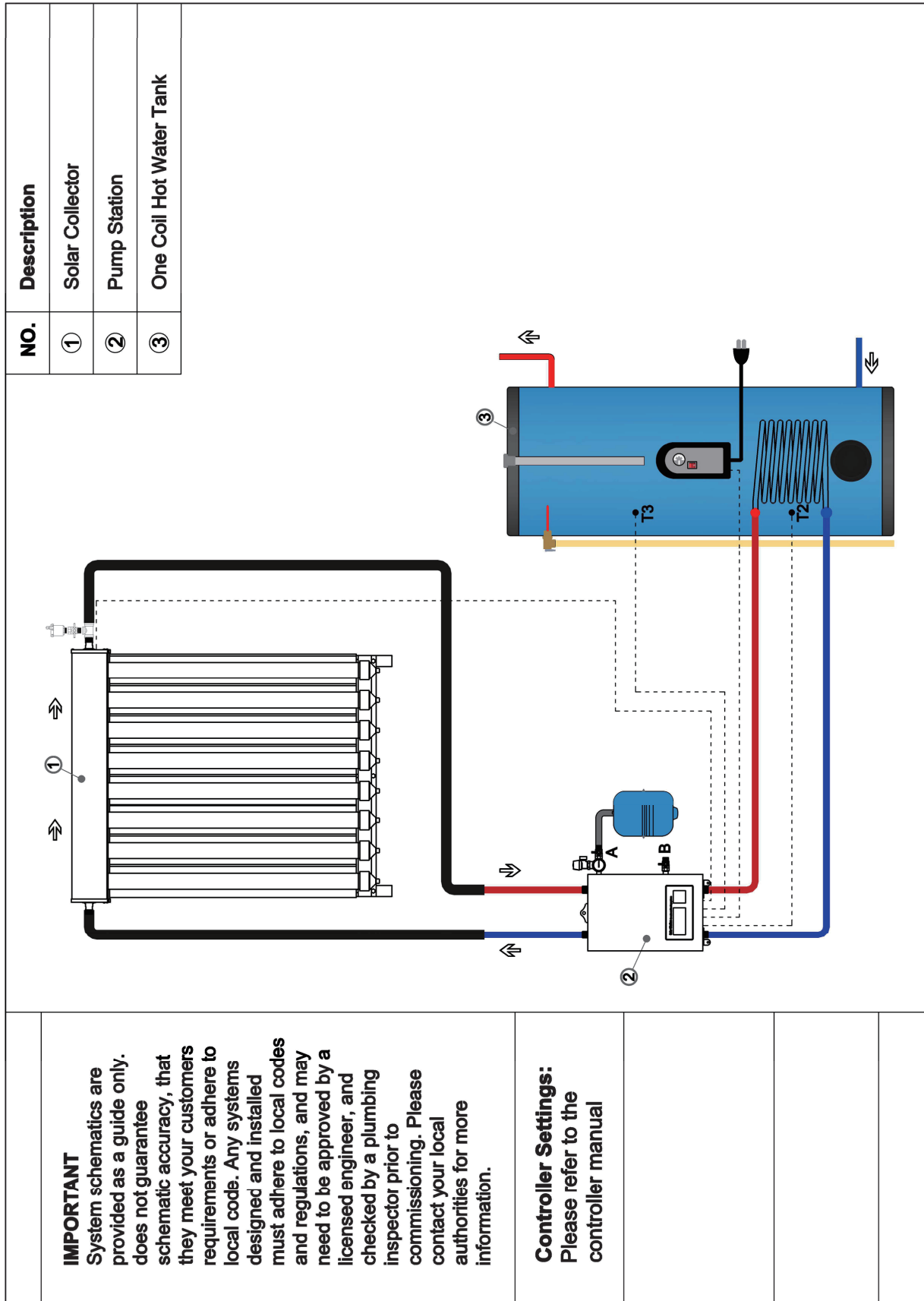

**IMPORTANT**  
System schematics are provided as a guide only. does not guarantee schematic accuracy, that they meet your customers requirements or adhere to local code. Any systems designed and installed must adhere to local codes and regulations, and may need to be approved by a licensed engineer, and checked by a plumbing inspector prior to commissioning. Please contact your local authorities for more information.

**Controller Settings:**  
Please refer to the controller manual

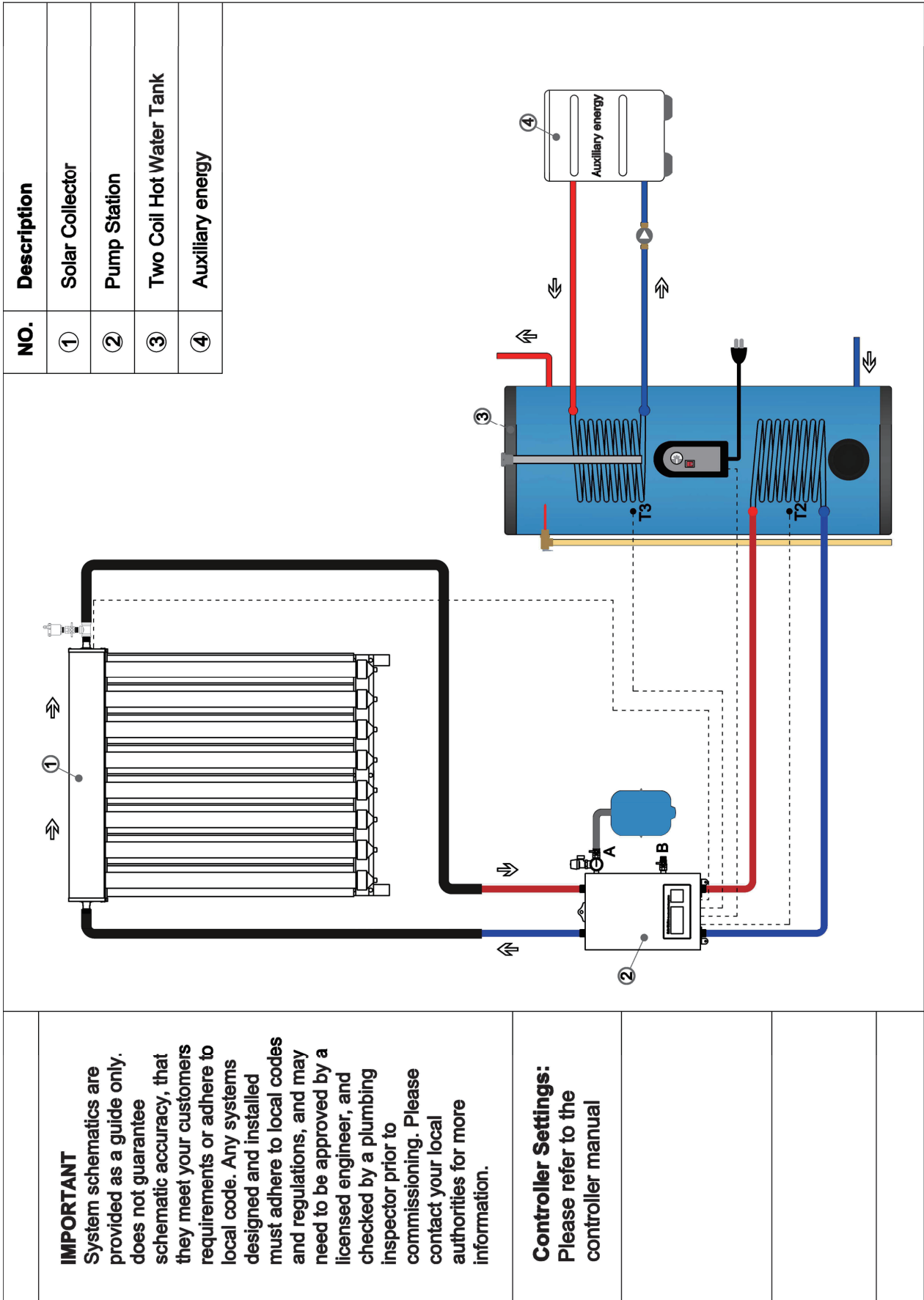



## 9. Dimensions of pipe connections

Qty.Tube(x)	Series and parallel	Main pipeline	Branch pipeline
$x \leq 36$	Series	$\frac{1}{2}$ or $\frac{3}{4}$ inch	$\frac{1}{2}$ or $\frac{3}{4}$ inch
$36 > x \leq 90$	Series	$\frac{3}{4}$ inch	$\frac{3}{4}$ inch
$90 > x \leq 120$	Series	$\frac{3}{4}$ inch	$\frac{3}{4}$ inch
$120 > x \leq 240$	Series and 2 parallel	1 inch	$\frac{3}{4}$ inch
$240 > x \leq 360$	Series and 3 parallel	$1\frac{1}{4}$ inch	$\frac{3}{4}$ inch
$360 > x \leq 480$	Series and 4 parallel	$1\frac{1}{2}$ inch	$\frac{3}{4}$ inch
$480 > x \leq 600$	Series and 5 parallel	2 inch	$\frac{3}{4}$ inch

In a standard heating system, we recommend that you use standard flexible stainless steel tube and stainless steel fittings when installing the collectors (or standard copper piping and copper fittings). The connection points of the pipes should be brazed or connected using olive connections due to the high stagnation temperatures. No galvanised pipes, galvanised fittings or graphite seals may be used. Hemp may only be used in conjunction with pressure and temperature resistant sealant. The components used must be resistant to the heat transfer medium. The thermal insulation of pipes outdoors must be temperature and UV radiation-resistant and resistant to bird damage. Under no circumstances can plastic pipe work or fittings be installed within the solar system.

## 10. Water quality

a) Water in direct flow through the manifold header must firstly meet potable water requirements, and in addition the following:

Total dissolved solids	< 600 p.p.m.	Total hardness	< 200 p.p.m.
Chloride	< 250 p.p.m.	Free Chlorine	< 5 ppm
Magnesium	< 10 p.p.m.		

b) In areas with "hard" water (>200ppm), lime scale may form inside the header pipe. In such regions, it is advisable to install a water softening device to ensure the long term efficient operation of the collector, or use a closed loop for the solar circulation loop.

c) If using a glycol/water mix, the water must meet the above requirements, and the glycol content of the liquid must not exceed 50%, unless the manufacture specifies that a different ratio is recommended for use with solar water heaters. Glycol may need to be changed periodically (every 3-5 years) to prevent the glycol from becoming acidic.

d) In order to meet health and safety regulations, only food grade polypropylene glycol or other heat transfer fluids should be used.

e) For areas with sustained winter temperatures below  $-5^{\circ}\text{C}$ , a closed loop filled with an anti-freeze heat transfer fluid should be used to provide freeze protection. Only food grade heat transfer fluids should be used.

## 11. Heat transfer liquid

It is advisable to use a closed loop system with a non-toxic grade polypropylene glycol used as the heat transfer liquid.

Filling heat transfer liquid step as follows (please refer to page 24):

- Disconnect the expansion vessel from the solar thermal system.
- Connect the flushing hose of a flushing and filling station to the drain ball valve (B) of pump station.
- Open the filling ball valve (A) and drain ball valve (B).
- Flush the solar thermal system using the flushing and filling station for at least 15 minutes to remove all air from the system.
- During the flushing, bleed the solar thermal system several times at the air stopper until the discharged solar fluid is free of air bubbles.
- Close the drain ball valve (B) of flushing and filling unit, and continue to run the pump and increase the system

pressure to approx.5 bar, system pressure can be read from the manometer.

- Close the filling ball valve (A) of pump station, and then close the filling pump.
- Check the manometer to see whether the system pressure reduces and eliminate leaks where necessary.
- Reconnect the expansion vessel to the solar thermal system.

Heat transfer liquid maintenance: please check the pressure gauge each month, if pressure drop into <2bar, please filling the heat transfer liquid again in the same way.

#### Heat transfer fluid maintenance & repair

- a) Heat transfer fluids that are exposed to stagnation temperature may break down over time, which will cause the fluid to become acidic and loose anti-freeze properties. It will general become "sludgy," which can reduce circulation efficiency. This is particularly the case for propylene glycols, but will also occur with "high-temp" rated glycols.
- b) Ideally, heat transfer fluid should be inspected and tested annually, but least once every 3 years. The following checks should be completed:
  - i) Check for cloudiness or sludging that would indicate indicate fluid breakdown.
  - ii) Check pH, should be within the range specified by the manufacturer.
  - iii) Use hydrometer to check freeze protection level.

## 12. Installation precautions

Note: In order to avoid jamming the digital flow meter and in result to display no flow on solar station, the filter must be installed on the return and flow pipeline of solar station.

All devices connected to the controller must conform to the technical specification of the controller. Assembly, Installation and maintenance work may only be performed by properly qualified and authorized personnel with a generally recongnized qualification.

The solar station must be installed indoors, prior to installation, remove sealing caps from solar station. The maximum distance between solar station and water tank is 300mm, keep top edges of solar station and top edges of storage tank.

Presetting, installing and adjusting the expansion tank as per the installation and operation instruction for " expansion tank ", the corrugated connection pipe for the expansion tank does not need thermal insulation.

Safety valve: Risk of scalding from hot steam with discharge from the safety valve due to heating and excess pressure in the hydraulic pipes. Drain off discharge from the safety valve using a copper pipe correctly and in an eco-friendly way, according to valid technical regulations and load codes, do not allow solar fluid to leak into the environment.

Be careful of scald from hot fluid. Maxium temperature of collectors during filling/leak check or installation /maintenance work should be below 45 °C , allow collectors to cool down if necessary.

## 13. Max. working pressure

Regardless of the installation configuration, pressure release values, expansion vessels and/or other pressure control devices must be installed. The solar loop should be designed to operate at no more than 1.2MPa. (1.2MPa=12bar=174psi) For installation where mains pressure water is used, the system should ideally be designed to operate at a pressure of <0.6MPa, achieved by use of a pressure limiting/reduction value.

## 14. Pressure drop at rated flow rate

Pressure drop through a 15 tube header at 2.7L/min and 20 °C is around 0.2kPa.

Pressure drop at higher temperature will be slightly lower.

## 15. Wind and snow load

When installing the collector please consider the issue of wind resistance and the resultant stress on the

attachment points. the standard frame is designed to withstand wind speeds of up to 120km/h and 30cm snow accumulation without damage. For the areas with possibility for high winds, additional reinforcement of attachment points may be required and can easily be supplied by your local installers.

## 16. Maintenance requirements

### 16.1 Cleaning

Regular rain should keep the evacuated tubes clean, but if particularly dirty they may be washed with a soft cloth and warm, soapy water or glass cleaning solution, If the tubes are not easily and safely accessible, high pressure water spray is also effective.

### 16.2 Leaves

During autumn, leaves may accumulate between or beneath the tubes. Please remove these leaves regularly to ensure optimal performance and to prevent a fire hazard.(The solar collector will not cause the ignition of flammable materials)

### 16.3 Broken tube

If a tube is broken it should be replaced as soon as possible to maintain maximum collector performance. The system will still operate normally even with a tube broken. Any broken glass should be cleared away to prevent injury.

